

HORQUILLA MÓVIL ECA 40

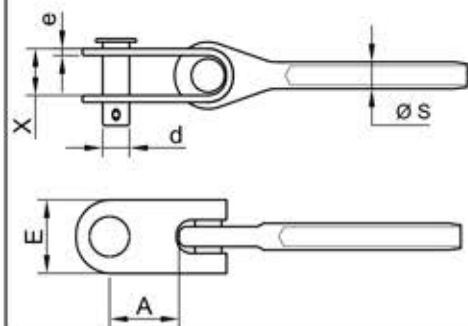

A	19
E	20
X	9
e	2,5
d	8
ØS	7,5

TENSOR HORQUILLA MÓVIL RCS 40

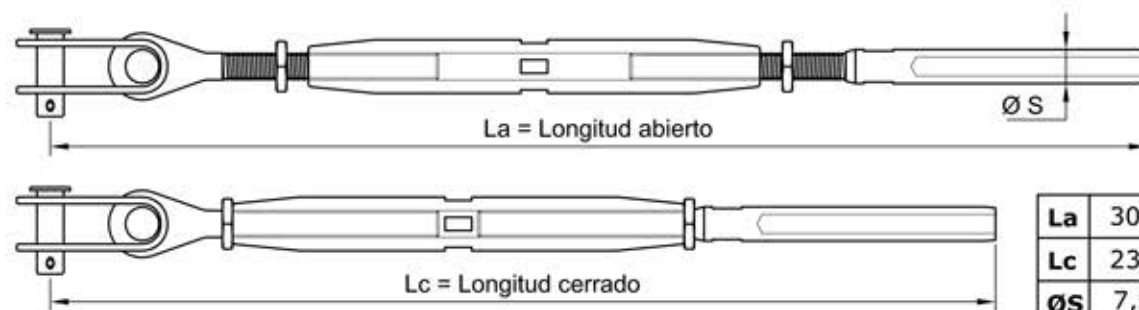

La	300
Lc	235
ØS	7,5

CABLE INOXIDABLE 316



7 x 19



Cable Ø	4
Carga rotura (Kg)	850
Composición	7x19
Calidad	AISI 316
Límite elástico	60 %

DIMENSIONADO DEL PUNTO DE ANCLAJE

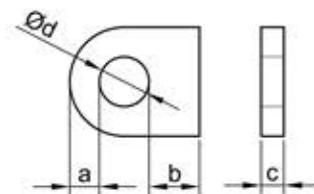

	Min	Max
a	9	13
b	12	X
c	5	8
d	9	X

IGENA, S.A.

Tel : 93 753 17 11
Fax : 93 753 31 59

HORQUILLA MÓVIL
TENSOR DE HORQUILLA MÓVIL

ECA 40 - RCS 40



Cotas en mm

Plano D01