

HORQUILLA MÓVIL ECA 40

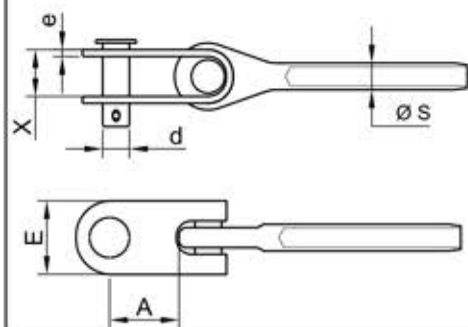

A	19
E	20
X	9
e	2,5
d	8
ØS	7,5

TENSOR HORQUILLA MÓVIL RCS 40

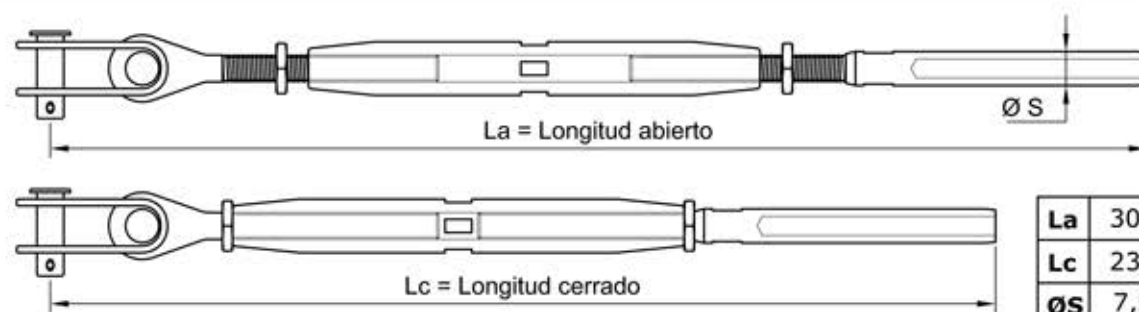

La	300
Lc	235
ØS	7,5

CABLE INOXIDABLE 316



1 x 19



Cable Ø	4
Carga rotura (Kg)	1.375
Composición	1x19
Calidad	AISI 316
Límite elástico	70 %

DIMENSIONADO DEL PUNTO DE ANCLAJE

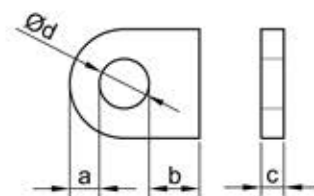

	Min	Max
a	9	13
b	12	X
c	5	8
d	9	X

IGENA, S.A. Tel : 93 753 17 11 Fax : 93 753 31 59	HORQUILLA MÓVIL TENSOR DE HORQUILLA MÓVIL	
	ECA 40 - RCS 40	Cotas en mm Plano A01